

PowerKit Engine 12M33 Series

General Specifications

Bore x Stroke	150 x 185 mm
Displacement	39.2 L
N° of Cylinders	12
Cylinders Arrangement	At Vee
Fuel System	Mechanical Pump
Governor (Gov.)	Electronic
Aspiration (Asp.)	T/A-A

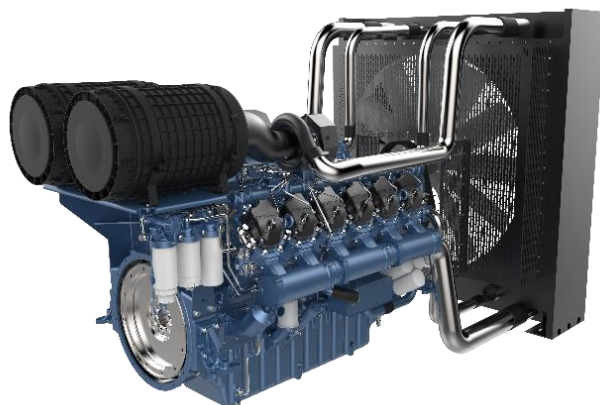

Diesel Engine		Gross Engine Output		Typical Generator Output				Asp.	Gov.
Model	Speed Rpm	Prime Power PRP kWm	Standby Power ESP kWm	Prime Power (PRP)		Standby Power (ESP)			
				kWe	kVA	kWe	kVA		
12M33G1250/5	1500	1007	1108	920	1150	1000	1250	T/A-A	Elec
12M33G1400/5	1500	1100	1210	1000	1250	1120	1400	T/A-A	Elec
12M33G1500/5 [^]	1500	1200	1320	1100	1375	1200	1500	T/A-A	Elec
12M33G1000/6	1800	1007	1108	900	1125	1000	1250	T/A-A	Elec
12M33G1100/6	1800	1150	1265	1000	1250	1100	1375	T/A-A	Elec
12M33G1200/6 [^]	1800	1200	1320	1092	1365	1200	1500	T/A-A	Elec
12M33G1300/6 [^]	1800	1290	1420	1176	1470	1300	1625	T/A-A	Elec

Aspiration : T/A-A = Turbocharged & Air-to-Air Aftercooled

[^] These engines are designed for emergency standby power (ESP) applications only. The indicated PRP Power is for reference only.

Standard Equipment

Engine and block

Cast iron cylinder block with inspection door per cylinder
 Cast iron cylinder liners, wet type and replaceable valves guides and seats
 Separate cast iron cylinder heads with 4 valves
 Hardened steel forged crankshaft with induction hardened journals, crankpins and radius
 Lube oil cooled light alloy pistons with high performance piston rings

Cooling system

Radiator and hoses supplied separately
 Thermostatically-controlled system with belt driven coolant pump and pusher fan

Lubrication system

Full flow screw able oil filters
 Lube oil purifier with replaceable cartridge
 Water cooled lube oil cooler

Fuel system

In line fuel injection pump with flanged electronic governor
 Duplex fine filter and water separation filter assembly with transparent cup for better efficiency
 Electric fuel priming pump integrated in the filters support

Air intake and exhaust system

Top mounted turbocharger optimized for genset application
 Special rear mounted air filter with restriction indicator
 Exhaust manifold and turbocharger shield for heat isolating

Electrical system

24 Vdc electric starter motor and battery charging alternator
 LOP + HWT sensors

Flywheel and housing

SAE 0 flywheel housing and 18" flywheel

PowerKit Engine 12M33 Series

Dimensions and Weight

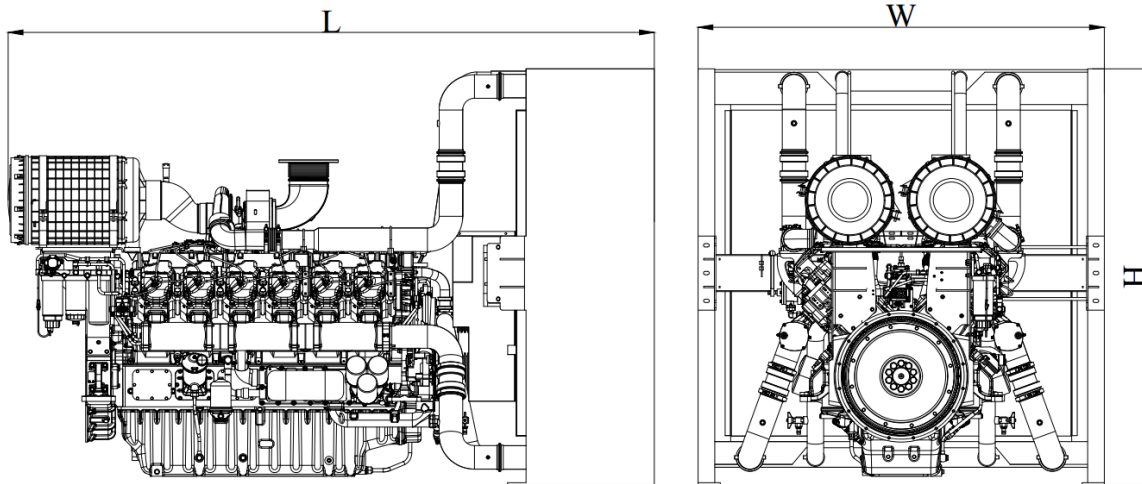

Diesel Engine		Dimensions and dry weights including radiator			
Model	Speed Rpm	L mm	W mm	H mm	Weight Kg.
12M33G1250/5	1500	3511	2192	2246	4395
12M33G1400/5	1500	3511	2192	2246	4395
12M33G1500/5	1500	3511	2192	2246	4395
12M33G1000/6	1800	3511	2192	2246	4395
12M33G1100/6	1800	3511	2192	2246	4395
12M33G1200/6	1800	3511	2192	2246	4395
12M33G1300/6	1800	3511	2192	2246	4395

Ratings definitions

Emergency Standby Power (ESP)

Emergency Standby Power is the maximum power available for a varying load for the duration of a main power network failure. The average load factor over 24 hours of operation should not exceed 70% of the engine's ESP power rating. Typical operational hours of the engine is 200 hours per year, with a maximum usage of 500 hours per year. This includes an annual maximum of 25 hours per year at the ESP power rating. No overload capability is allowed. The engine is not to be used for sustained utility paralleling applications.

Unlimited Prime Rated Power (PRP)

Prime Power is the maximum power available for unlimited hours of usage in a variable load application. The average load factor should not exceed 70% of the engine's PRP power rating during any 24 hour period. An overload capability of 10% is available, however, this is limited to 1 hour within every 12 hour period.

Continuous Power (COP)

Continuous Power is the maximum power available for an unlimited period of use at a constant load factor. No overload capability is allowed.

- 1) All ratings are based on operating conditions under ISO 8528-1, ISO 3046, DIN6271. Performance tolerance of $\pm 5\%$.
- 2) Test conditions : 100 kPa, 25°C air inlet temperature, relative humidity of 30%, with fuel density 0.84 kg/L. Derating may be required for conditions outside these; please contact the factory for details.
- 3) Power output curves are based on the engine operating with fuel system, water pump and lubricating oil pump; not included are battery charging alternator, fan and optional equipment.