

mariner 70 MTS - 84 MTS



CONTROL PANEL



PERKINS ENGINE



INPUT/OUTPUT FUEL PIPE

the engine is cooled by a coolant loop in a closed circuit. The system consists of a heat exchanger, inside which the heat exchange between coolant and sea water takes place. Two separate pumps provide for the circulation of coolant and seawater. Air flows ensure effective cooling of the alternator. The excellent accessibility makes maintenance operations easier, even with the generator installed in confined environments.



COMPACT DESIGN



EASY INSTALLATION



SUPER SILENCED

We reserve the right to modify the data, images and drawings in this document without prior notice.

For more detailed information, please contact your local distributor or Mase Generators S.p.A.



mase generators spa

Via Tortona, 345 | 47522 - Cesena (FC) | Italy

Tel. +39 0547 354311

commercial@masegenerators.com

www.masegenerators.com

mase
GENERATORS
Believing in change.



Single-phase output power
72 kVA 50 Hz - 84 kVA 60 Hz

CONTROL PANEL

_ CBU EVO IL4 device controls and drives the genset. The large display and control pushbuttons allow easy use and monitoring:

- Manual start
- Voltage Vac
- Frequency Hz
- Hour meter
- Genset battery voltage
- Oil low pressure alarm
- Engine preheating
- Engine high temperature alarm
- Alternator battery charger failure alarm
- Protection alarm for frequency and rpm
- Alarm history
- Maintenance warnings
- General alarm outlet
- RUN outlet
- Ready outlet
- Programmable AUX outlet

_ Emergency stop button

_ Magneto-thermal protection

ENGINE

_ Easy maintenance access to the feeding and lubrication systems, the sea water pump and the air filter

_ Double vibration dumping system

_ Oil drain pump

SOUNDPROOF CABIN

_ Made of extremely light marine aluminum with very high resistance to external agents

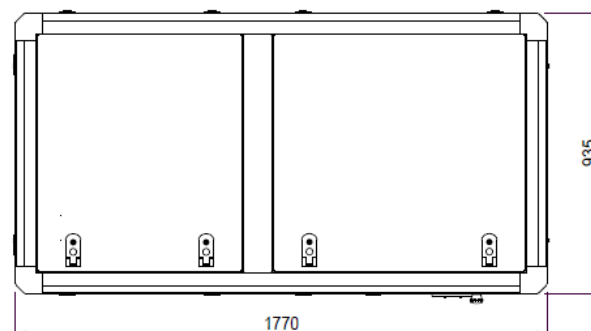
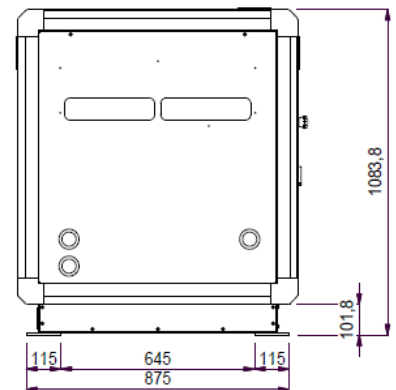
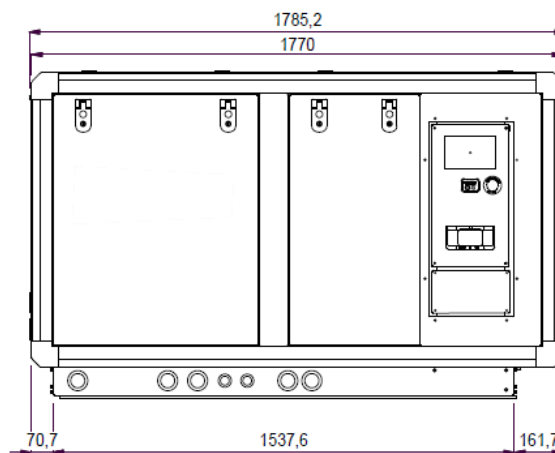
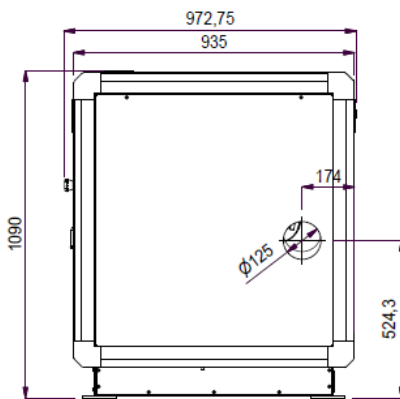



Single-phase output power
72 kVA 50 Hz - 84 kVA 60 Hz

50 Hz

60 Hz

AC alternator -	Synchronous, 4 poles, with AVR	
Cooling -	Air	
Voltage -	400 V	480 V
Frequency -	50 Hz	60 Hz
Amps -	104 A	101.2 A
Max power -	72 kVA	84 kVA
Continuous power -	65 kVA	74 kVA
Power Factor -	cos ϕ 0.8	
Insulating class -	H	
Voltage stability -	$\pm 2\%$	
Frequency stability -	$\pm 5\%$	

The power is referred to an atmospheric pressure of 100 kPa, a humidity percentage of 30% and an ambient temperature of 25°C.

Model -	Perkins 1104A-44TG1	
Type -	Diesel	
Cylinders -	nr 4	
Cylinder block material -	Cast iron	
Bore -	105 mm - 4.14 in	
Stroke -	127 mm - 5 in	
Displacement -	4400 cc - 268.51 CID	
Power -	86.2 hp - 63.41 kWm	101.2 hp - 74.44 kWm
RPM -	1500	1800
Compression ratio -	17.25:1	
Combustion system -	Direct injection	
Engine head material -	Cast iron	
Speed governor -	Electronic	
Lubrication system -	Forced	
Oil sump capacity with filter -	6.5 l - 1.83 gl	
Engine stop system -	Solenoid valve	
Fuel pump -	Electric	
Max. fuel pump head -	700 mm - 27.5 in	
Fuel consumption -	14.8 l/h - 3.91 gl/h	17.7 l/h - 4.68 gl/h
Air intake -		
Starting battery -	80 Ah - 12 V	
Battery charger -	40 Ah - 12 V	
Starter motor -	12 kW - 12 V	
Max. inclination -	25°	
Water pump flow -	86 l/min - 22.71 gl/min	
Sea water inlet pipe \varnothing -	25 mm - 1"	
Exhaust pipe \varnothing -	102 mm - 4"	
Input/Output fuel pipe \varnothing -	8 mm - 5/16"	
Dimensions (L x W x H) -	1770 x 935 x 1085 mm - 69.7 x 36.8 x 42.7 in (with soundproof box)	
Weight -	1000 Kg - 2205 lb (with soundproof box)	
Noise Level -	58 dBA at 7 mt (23 ft)	59 dBA at 7 mt (23 ft)



Single-phase output power
72 kVA 50 Hz - 84 kVA 60 Hz

Accessory

Code

ACCESSORIES ON REQUEST

• Filtering kit: sea water inlet, sea water strainer, taps, fittings D.25 - ref.4	03793
• Exhaust kit: muffler, silencer, exhaust outlet D.90 VETUS	038325
• Siphon break D.25 - ref.3	015849
• Vetus LP90 muffler	71688
• Vetus MP90 silencer	71690
• Centek 3" 1/2 muffler	71689
• Centek 3" 1/2 water/gas separator	71692
• Remote START/STOP panel with 20m cable for Comap IL4 - ref.1	037561
• Comap IL4 remote start panel with 20m cable - ref.2	039607
• Cruise Kit	913848



.1



.2

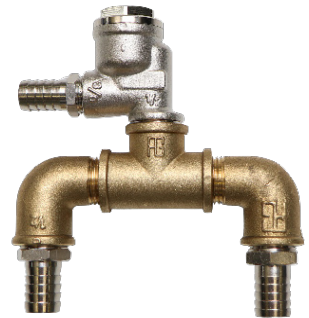

.3

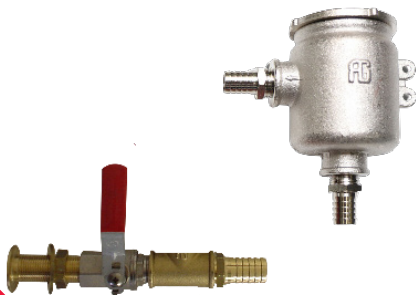

.4