

# VS 10.6 DV

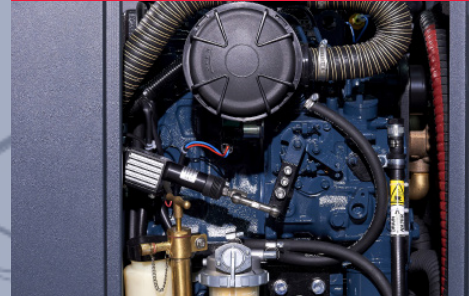

CONTROL PANEL



KUBOTA ENGINE



INPUT/OUTPUT FUEL PIPE

**the** engine revs vary depending on the required load; therefore, if you have only few electrical applications connected, the genset will automatically calibrate to the required power, while ensuring exceptional voltage and frequency stability. That means lower fuel consumption, reduction of emissions, lower need of maintenance and more silent operation. Extremely compact and quiet, the genset is equipped with a double shock absorbing system to increase comfort: the first one absorbs vibrations from engine-alternator to the frame, the second one absorbs residual micro-vibrations from frame to vessel.

We reserve the right to modify the data, images and drawings in this document without prior notice.

For more detailed information, please contact your local distributor or Mase Generators S.p.A.



COMPACT DESIGN



EASY INSTALLATION



SUPER SILENCED



**mase generators spa**

Via Tortona, 345 | 47522 - Cesena (FC) | Italy

Tel. +39 0547 354311

commercial@masegenerators.com

www.masegenerators.com

**mase**  
**GENERATORS**  
*Believing in change.*



### CONTROL PANEL

\_ CBU EVO IL4 device controls and drives the genset. The large display and control pushbuttons allow an easy use and monitoring:

- Manual start
- Voltage Vac
- Frequency Hz
- Engine rpm
- Hour meter
- Genset battery voltage
- Oil low pressure alarm
- Engine preheating
- Engine high temperature alarm
- Alarm history
- Maintenance warnings

\_ Emergency stop button

\_ Protection against short circuit and overload

### ENGINE

\_ Easy maintenance access to the feeding and lubrication systems, the sea water pump and the air filter

\_ Double vibration dumping system

\_ Oil drain pump

### SOUNDPROOF CABIN

\_ Made of extremely light marine aluminum with very high resistance to external agents

Insulated poles kit (for metal hull boats), dry exhaust kit and keel cooling kit are available on request

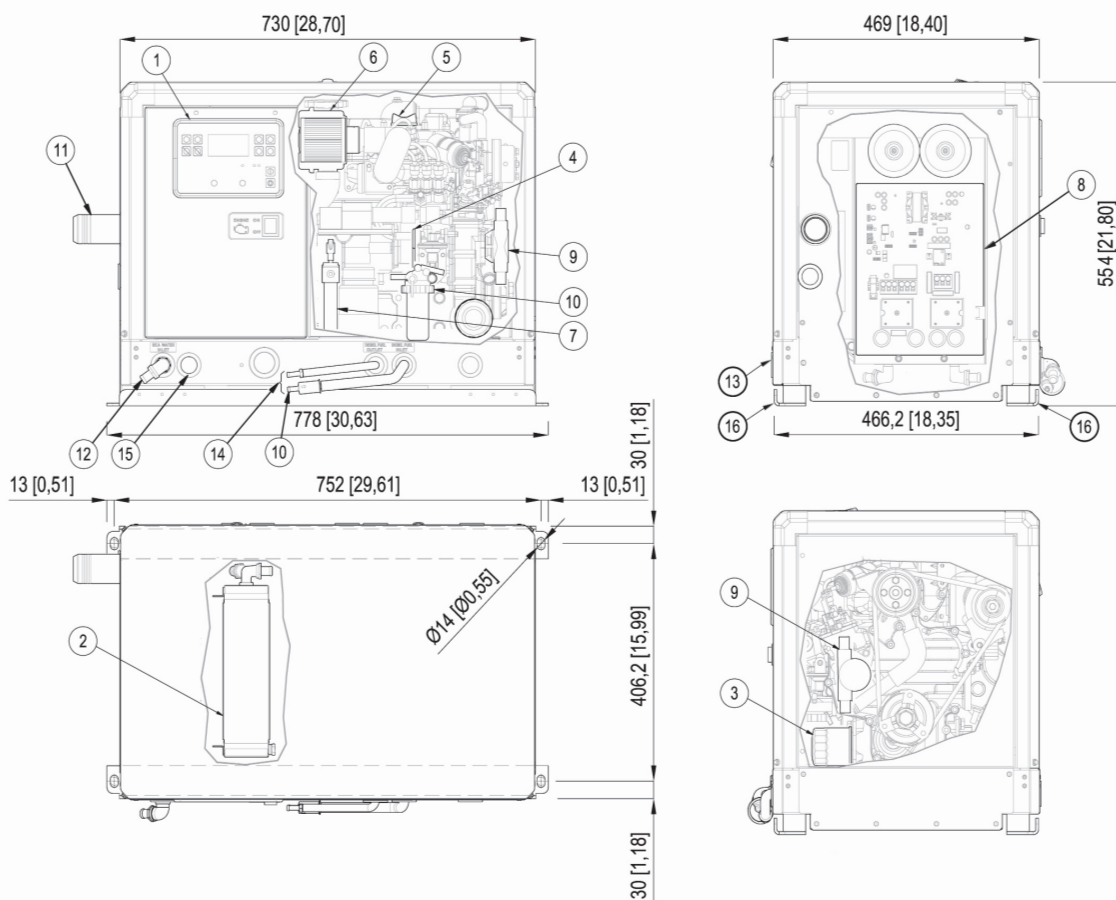

- |                          |                   |                                |                                    |
|--------------------------|-------------------|--------------------------------|------------------------------------|
| 1. Control panel         | 6. Air filter     | 11. Exhaust manifold (d.50 mm) | 14. Fuel tank connections (d.8 mm) |
| 2. Air / water exchanger | 7. Oil drump pump | 12. Sea water intake (d.16 mm) | 15. Cables outlet                  |
| 3. Oil filter cartridge  | 8. Inverter       | 13. Battery connections        | 16. Genset fixing brackets         |
| 4. Oil dipstick          | 9. Sea water pump |                                |                                    |
| 5. Engine oil filler     | 10. Fuel filter   |                                |                                    |



## Output power 10 kW

**DATA SHEET**

AC alternator -	Permanent magnets (PMG)
Cooling -	Air / Water (Intercooler W / A)
Voltage -	115 or 240 V
Frequency -	50/60 Hz
Amps -	87 or 41.7 A
Continuous power -	10 kW
Power Factor -	cos ø 1
Insulating class -	H
Voltage stability -	±1%
Frequency stability -	±1%

The power is referred to a sea water temperature up to 31°, an atmospheric pressure of 100 KPa and a humidity percentage of 30%

Model -	KUBOTA D722
Type -	Diesel 4 stroke
Cylinders -	nr 3
Cylinder block material -	Cast iron
Bore -	67 mm - 2.64 in
Stroke -	68 mm - 2.68 in
Displacement -	719 cc - 43.88 CID
Power -	16.6 hp - 12.21 kWm (at 3150 RPM)
RPM -	2150 - 3150
Compression ratio -	23.5:1
Combustion system -	Indirect injection
Engine head material -	Cast iron
Speed governor -	Electronic with actuator
Lubrication system -	Forced
Oil sump capacity with filter -	2.7 l - 0.76 gal
Engine stop system -	Electromagnet
Fuel pump -	Electric
Max. fuel pump head -	700 mm - 27.5 in
Fuel consumption -	4.24 l/h - 1.12 gal/h
Starting battery -	65 Ah - 12 V
Battery charger -	30 Ah - 12 V
Starter motor -	1 kW - 12 V
Max. inclination -	25°
Water pump flow -	22 l/min - 5.8 gal/min
Sea water inlet pipe Ø -	16 mm - 5/8"
Exhaust pipe Ø -	50 mm - 2"
Input/Output fuel pipe Ø -	8 mm - 5/16"
Dimensions (L x W x H) -	730 x 469 x 554 mm - 28.70 x 18.40 x 21.80 in (with soundproof box)
Weight -	183 Kg - 404 lb (with soundproof box)
Noise Level -	54 dBA at 7 mt (23 ft)



### Accessory

### Code

#### ACCESSORIES ON REQUEST

• Installation kit D.50: filtering set, exhaust set and siphon break D.16	012276
• Filtering kit: sea water inlet, sea water strainer, taps, fittings D.16 - ref.5	04349
• Mase exhaust kit: sea water lock, silencer, outlet D.50 - ref.3	04658
• Mase super silenced exhaust kit & exhaust gas separator D.50 - ref.6	010078
• Siphon break D.16 - ref.4	04290
• Mase Muffler D.50	70795
• Silencer Mase D.50	71809
• Mase water/gas exhaust separator D.50	04488
• Vetus LP50 muffler	71148
• Vetus silencer MP50	71751
• Silencer Vetus c.71751 with soundproofing sponge	039866
• Vetus Separator LGS5038	71717
• Centek muffler 2"	71155
• Centek 2" water/gas exhaust separator	71156
• Water protection	040539
• Parallel cable	036625
• Soundproofing cabin	038032
• Remote control panel START/STOP with 20 mt cable for Comap IL4 - ref.1	037561
• Remote control panel for Comap IL4 with 20mt cable - ref.2	039607
• Cruise KIT	913651



.1



.2



.3



.4

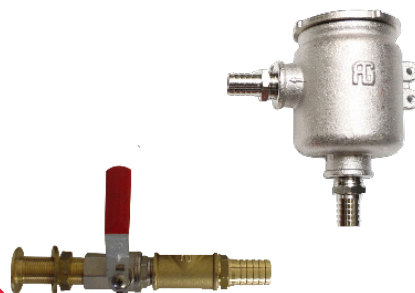

.5



.6