

HYUNDAI DP222CB



50/60Hz
MULTI
FREQUENCY
GENERATOR



GENERATOR



Fuel
Optimized

Description

- HD Hyundai Infracore, which has been engaged in engine production and development since 1958, introduces a new generator electronic engine DP222 C-Series.
- When compared to other engines of equivalent capacity, it displays a higher output, better fuel efficiency, higher safety, and easier maintenance and is expected to become the key product of HD Hyundai Infracore.



Features

[High Power & Economy]

- High performance & Low fuel/oil consumption
- 50/60 Hz switchable without Power De-rating
- G3 Class(ISO 8528-5)

[High Durability]

- High strength design for main structure parts
- Higher warranty period through sufficient verification
- 1000hrs /5years (ESP), Unlimited /1year (PRP)

[Convenience & Safety]

- Oil maintenance interval: 500hrs without replenishment
- Auto tensioning belt drive system
- Radiator to cover a wide range of usage condition
- Safety guard for hazard parts
- Meet REACH & RoHS regulations

Power

	50 Hz / 1500 rpm									60 Hz / 1800 rpm								
	Standby Power			Prime Power			Continuous Power			Standby Power			Prime Power			Continuous Power		
	kWm	kWe	kVA	kWm	kWe	kVA	kWm	kWe	kVA	kWm	kWe	kVA	kWm	kWe	kVA	kWm	kWe	kVA
DP222CB	790	727	908	705	646	808	501	454	567	890	806	1008	810	730	913	578	511	639

Generator efficiency (typical) :

kWm= kiloWatt mechanical, net with fan*; kWe= kiloWatt electrical = kWm x Generator eff.; kVA= kiloVoltAmpere calculations based on a 0.8 power factor = kWe/0.8

1kW= 1 hp x 1.36; 1hp= 1kW x 0.7355

*Based upon technical data



General Data

Type	Diesel, water cooled, Turbo charged & intercooled
Bore	128mm
Stroke	142mm
Displacement liter	21.9
Cylinders and Arrangement	Cast iron, 12 cylinder, Vee-Type
Battery charging alternator	24V x 45A alternator
Starting voltage	24V
Fuel System	Common Rail Direct Injection Controlled by ECU
Fuel Filter	Main(On Engine): Full flow, High efficiency dust in fuel filter, cartridge type Pre(Loosed Part): Full flow, cartridge type with water drain valve
Lube oil filter type(s)	Full flow, cartridge type
Lube oil capacity (l)	Max. 75 liters , Min. 23 liters
Flywheel dimensions	Clutch No. 18 M

Coolpac Data

Cooling method	Jacket Water and Charge Air Cooled	
Cooling ratio	50% ethylene glycol; 50% water	
Water capacity (L)	with radiator	66liters
	without radiator	24liters
Fan power (kWm)	21kW(50Hz), 37kW(60Hz)	
Cooling system air flow(m ³ /s)	21.1(50Hz), 25.2(60Hz)	

Fuel Consumption

Fuel Consumption 1500 (50Hz)

%	kWm	BHP	Liters/hr	USgal/hr
Standby Power				
100	790.0	1059.4	190.0	50.19
Prime Power				
100	705.0	945.4	190.0	50.19
75	528.8	709.1	146.0	38.57
50	352.5	472.7	102.0	26.95
25	176.3	236.4	63.0	16.64
Continuous Power				
100	501.0	671.8	128.0	33.81

Fuel Consumption 1800 (60Hz)

%	kWm	BHP	Liters/hr	USgal/hr
Standby Power				
100	890.0	1193.5	216.0	57.06
Prime Power				
100	810.0	1086.2	216.0	57.06
75	607.5	814.7	166.0	43.85
50	405.0	543.1	117.0	30.91
25	202.5	271.6	73.0	19.28
Continuous Power				
100	578.0	775.1	145.0	38.3



Dimensions

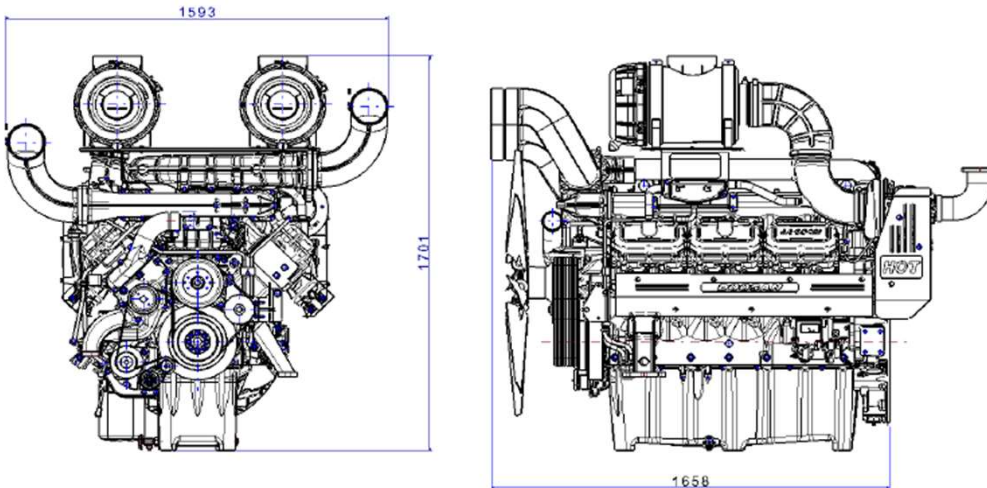

Weights and Dimensions

Length mm	Width mm	Height mm	Weight (dry) kg
1,658	1,593	1,701	1,676

Power Rating Guide

The power ratings of Emergency Standby and Prime are in accordance with ISO 8528. Fuel Stop power in accordance with ISO 3046.

Electric power (kWe) must be considered cooling fan loss, alternator efficiency, altitude derating and ambient temperature.

ESP(STANDBY POWER) is applicable for supplying emergency power for the duration of the utility power outage.

No overload capability is available for this rating.

A standby rated engine should be sized for a maximum of an 70% average load factor and 200 hours of operation per year. This includes less than 25 hours per year at the Standby Power rating.

PRP(PRIME POWER) is available for an unlimited number of hours per year in variable load application. Variable load should not exceed a 70% average of the Prime Power rating during any operating period of 24 hours.

The Total operating time at 100% Prime Power shall not exceed 500 hours per year.

A 10% overload capability is available for a period of 1 hour within a 12 hour period of operation.

Total operating time at the 10% overload power shall not exceed 25 hours per year.

COP(CONTINUOUS POWER) is defined as being the maximum power which the generating set is capable of delivering continuously whilst supplying a constant electrical load when operated for an unlimited number of hours per year under the agreed operating conditions with the maintenance intervals and procedures being carried out as prescribed by the manufacturer.

※ Specifications are subject to change without prior notice.

