

# HYUNDAI

# DP034CCV



GENERATOR



3.4L / 4 CYLINDERS



SWITCHABLE



EU STAGE V

## DESCRIPTION

- HD Hyundai Infracore's compact electronic engines, DP034C- Series is one of the key products.
- When compared to other engines of equivalent capacity, it displays a higher output, better fuel efficiency, higher safety, and easier maintenance.
- It has been recognized in the market even with the high emission standard EU Stage V and EPA/CARB Tier4F and satisfied its customers.

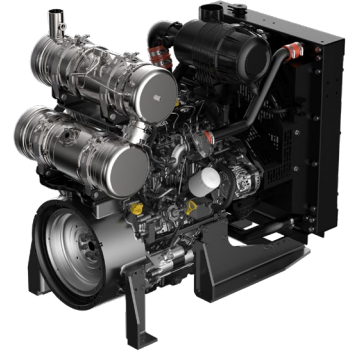

## FEATURES & BENEFITS

### [Low Emission]

- Meet EU Stage V
- No EGR system above 56kW

### [Performance & Fuel Economy Improvement]

- Bosch 1,800bar common rail system
- Ultra low fuel consumption
- Air management improved through optimization of valve timing & turbocharger matching

### [Convenience & TCO]

- Maintenance free for valve clearance
- Auto tensioner belt drive system
- Oil level sensor option for 1,000hrs exchange interval

## OUTPUT

1,500 RPM (50Hz)									1,800 RPM (60Hz)								
Standby			Prime			Continuous			Standby			Prime			Continuous		
kWm	kWe	kVA	kWm	kWe	kVA	kWm	kWe	kVA	kWm	kWe	kVA	kWm	kWe	kVA	kWm	kWe	kVA
78.1	68.6	85.7	73.8	64.7	80.9	51.7	44.8	56.0	92.4	80.2	100.2	84.8	73.3	91.6	59.4	50.5	63.1

- Generator efficiency (typical) : 90.0%
- kWm= kilo Watt mechanical, Gross power; kWe= kilo Watt electric = (kWm-Fan loss) x Generator eff.  
kVA= kilo Volt Ampere
- Calculations based on a 0.8 power factor = kWe/0.8

# DP034CCV

## GENERAL DATA

Type	Diesel, water cooled, Turbo charged & intercooled
Bore	98mm
Stroke	113mm
Displacement liter	3.41
Cylinders and Arrangement	Cast iron, 4 cylinder, In-line Type
Battery charging alternator	12V x 110A
Starting voltage	12V
Fuel system	Common Rail, Direct Injection Controlled by ECU
Fuel filter	Full flow, cartridge type
Lube oil filter type (s)	Full flow, cartridge type
Lube oil capacity (l)	Max. 12.6 liters , Min. 6.0 liters
Flywheel dimensions	Clutch 11 1/2" (SAE J620)

## COOLING SYSTEM

Cooling method	Fresh water forced circulation	
Cooling ratio	50% ethylene glycol; 50% water	
Water capacity (L)	with radiator	12.1 liters
	Without radiator	4.7 liters
Fan power (kW)	1.9 kW (50Hz), 3.3 kW (60Hz)	
Cooling system air flow (m <sup>3</sup> /min)	-	

## FUEL CONSUMPTION

### 1,500 RPM (50Hz)

%	kWm	BHP	Liters/hr	USgal/hr
<b>Standby Power</b>				
100	78.1	104.7	18.9	4.99
<b>Prime Power</b>				
100	73.8	99.0	17.8	4.70
75	55.3	74.2	13.3	3.51
50	36.9	49.5	9.1	2.40
25	18.4	24.7	5.2	1.37
<b>Continuous Power</b>				
100	51.7	69.3	-	-

### 1,800 RPM (60Hz)

%	kWm	BHP	Liters/hr	USgal/hr
<b>Standby Power</b>				
100	92.4	123.9	-	-
<b>Prime Power</b>				
100	84.8	113.7	-	-
75	63.6	85.3	-	-
50	42.4	56.9	-	-
25	21.2	28.4	-	-
<b>Continuous Power</b>				
100	59.4	79.7	-	-

# DP034CCV

## DIMENSIONS

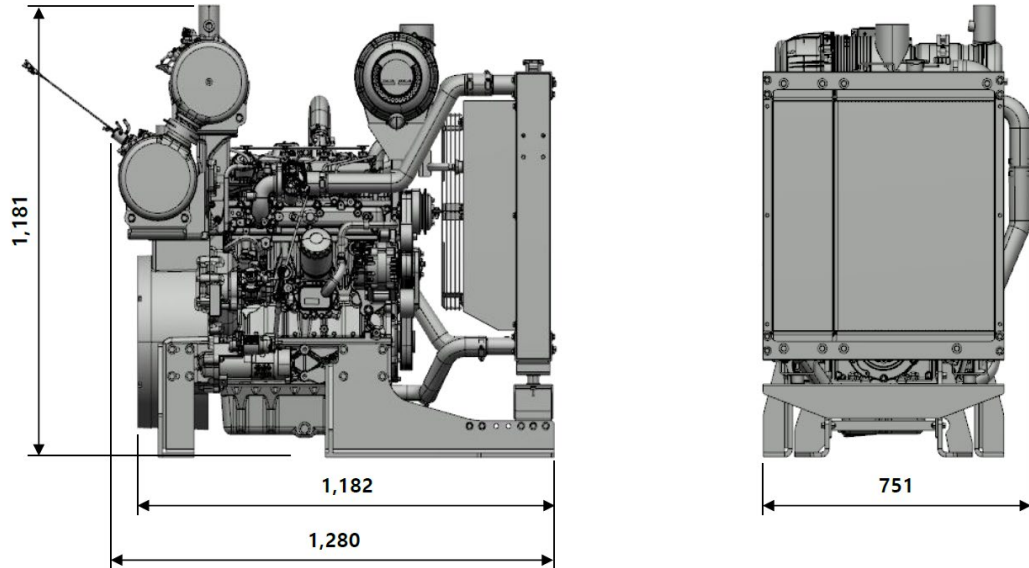

Weights and Dimensions

Item	Length (mm)	Width (mm)	Height (mm)	Dry Weight (kg)
Engine with ATS	937	685	1,129	373
G-Pack	1,280	751	1,181	518*

\* Except Mounting Bracket

## POWER RATING GUIDE

The power ratings of Emergency Standby and Prime are in accordance with ISO 8528. Fuel Stop power in accordance with ISO 3046. Electric power (kWe) must be considered cooling fan loss, alternator efficiency, altitude derating and ambient temperature.

**ESP(STANDBY POWER)** is applicable for supplying emergency power for the duration of the utility power outage. No overload capability is available for this rating. A standby rated engine should be sized for a maximum of an 70% average load factor and 200 hours of operation per year. This includes less than 25 hours per year at the Standby Power rating.

**PRP(PRIME POWER)** is available for an unlimited number of hours per year in variable load application. Variable load should not exceed a 70% average of the Prime Power rating during any operating period of 24 hours. The Total operating time at 100% Prime Power shall not exceed 500 hours per year. A 10% overload capability is available for a period of 1 hour within a 12 hours period of operation. Total operating time at the 10% overload power shall not exceed 25 hours per year.

**COP(CONTINUOUS POWER)** is defined as being the maximum power which the generating set is capable of delivering continuously whilst supplying a constant electrical load when operated for an unlimited number of hours per year under the agreed operating conditions with the maintenance intervals and procedures being carried out as prescribed by the manufacturer.

※ Specifications are subject to change without prior notice.