

DOOSAN INFRACORE GENERATOR ENGINE

DP086TA

Ratings (kWm/PS)	Gross Engine Output		Net Engine Output	
	Standby	Prime	Standby	Prime
1500rpm(50Hz)	152/207	137/186	147/200	132/179
1800rpm(60Hz)	187/254	168/228	179/243	160/218

Ratings Definitions

The power ratings of Emergency Standby and Prime are in accordance with ISO 8528.

Fuel Stop power in accordance with ISO 3046.

Electric power (kWe) must be considered cooling fan loss, alternator efficiency, altitude derating and ambient temperature.

STANDBY POWER RATING is applicable for supplying emergency power for the duration of the utility power outage.

No overload capability is available for this rating. A standby rated engine should be sized for a maximum of an 80% average load factor and 200 hours of operation per year. This includes less than 25 hours per year at the Standby Power rating.

PRIME POWER RATING is available for an unlimited number of hours per year in variable load application. Variable load should not exceed a 70% average of the Prime Power rating during any operating period of 24 hours. The Total operating time at 100% Prime Power shall not exceed 500 hours per year. A 10% overload capability is available for a period of 1 hour withing a 12 hour period of operation. Total operating time at the 10% overload power shall not exceed 25 hours per year.

◎ GENERAL ENGINE DATA

○ Engine Model	DP086TA
○ Engine Type	4-Cycle, In-line, 6-Cylinder Diesel, water cooled, Turbo charged
○ Bore x stroke	111 x 139 mm
○ Displacement	8.071 liters
○ Compression ratio	16.7 : 1
○ Rotation	Counter clockwise viewed from Flywheel
○ Firing order	1-5-3-6-2-4
○ Injection timing	19° ± 1° BTDC
○ Dry weight	790kg(with Fan)
○ Dimension (LxWxH)	1,242 x 746 x 1,113 mm
○ Fly wheel housing	SAE NO.1M
○ Fly wheel	Clutch NO.14M
○ Number of teeth on flywheel	102

◎ ENGINE MOUNTING

Maximum Bending Moment at Rear Face to Block	1325 N · M
--	------------

◎ EXHAUST SYSTEM

Maximum Back Pressure	5.9 kPa
-----------------------	---------

◎ AIR INDUCTION SYSTEM

Maximum Intake Air Restriction	
. With Clean Filter Element	2.16 kPa
. With Dirty Filter Element	6.23 kPa
○ Max. static pressure after Radiator	0.125 kPa



◎ COOLING SYSTEM

Water circulation by centrifugal pump on engine.

○ Cooling method	Fresh water forced circulation
○ Coolant capacity	Engine Only : Approx. 14 lit., With Radiator : Approx 44 lit.(standard)
○ Coolant flow rate	166 liters / min
○ Pressure Cap	Max. 49 kPa
○ Water Temperature	
- Maximum for standby and Prime	103°C
- Before start of full load	40.0°C
○ Water pump	Centrifugal type driven by belt
○ Thermostat Type and Range	Wax – pellet type, Opening temp. 71°C , Full open temp. 85°C
○ Cooling fan	Blower type, Plastic , 660 mm diameter, 7 blade
○ Max. external coolant system restriction	Not Available

◎ LUBRICATION SYSTEM

Force-feed lubrication by gear pump, lubricating oil cooling in cooling water circuit of engine.

○ Lub. Method	Fully forced pressure feed type
○ Oil pump	Gear type driven by crank-shaft gear
○ Oil filter	Full flow, cartridge type
○ Oil pan capacity	Max. 15.5 liters , Min. 12 liters
○ Lub oil pressure	Idle Speed : Min 100 kPa Governed Speed : Min 250 kPa
○ Maximum oil temperature	120°C
○ Angularity limit	Front down 15 deg , Front up 15 deg , Side to side 15 deg
○ Lubrication oil	Refer to Operation Manual

◎ FUEL SYSTEM

Bosch type in-line pump with integrated, electromagnetic actuator.

○ Injection pump	WUXI WEIFU HIGH-TECH CO.,LTD
○ Governor	Electric type (all speed control)
○ Speed drop	G3 Class (ISO 8528)
○ Feed pump	Mechanical type in injection pump
○ Injection nozzle	Multi hole type
○ Opening pressure	21.0 MPa
○ Fuel filter	Full flow, cartridge type with water drain valve
○ Maximum fuel inlet restriction	10 kPa
○ Maximum fuel return restriction	60 kPa
○ Fuel feed pump Capacity	175 liters / hr
○ Used fuel	Diesel fuel oil

◎ ELECTRICAL SYSTEM

○ Battery Charging Alternator	28.5V x 45A alternator
○ Voltage regulator	Built-in type IC regulator
○ Starting motor	24V x 6.0 kW
○ Battery Voltage	24V
○ Battery Capacity	100 Ah (recommended)
○ Starting aid (Option)	Block heater

◎ VALVE SYSTEM

○ Type	Overhead valve type	
○ Number of valve	Intake 1, exhaust 1 per cylinder	
○ Valve lashes at cold	Intake 0.3mm , Exhaust 0.3mm	
○ Valve timing	Opening	Close
- Intake valve	16 deg. BTDC	36 deg. ABDC
- Exhaust valve	46 deg. BBDC	14 deg. ATDC

◎ PERFORMANCE DATA

		Prime Power		Standby Power	
○ Governed Engine speed	rpm	1500	1800	1500	1800
○ Engine Idle Speed	rpm	800	800	800	800
○ Over speed limit	rpm	1650	1980	1650	1980
○ Gross Engine Power Output	kW	137	168	152	187
	ps	186	228	207	254
○ Break Mean effective pressure	Mpa	1.36	1.39	1.51	1.55
○ Mean Piston Speed	m/s	6.95	8.34	6.95	8.34
○ Friction Power	kW	18	24	18	24
	ps	24.47	32.63	24.47	32.63
○ Specific fuel consumption					
25% load	liters/hr	9.2	11.5	10.1	12.7
50% load	liters/hr	17.4	21.0	18.2	22.9
75% load	liters/hr	25.5	30.3	27.2	33.7
100% load	liters/hr	33.7	41.3	37.9	46.0
○ Maximum Lube oil consumption	g/h	130.4	159.9	144.7	178.0
○ Fan Power	kW	5	8	5	8
○ Sound Pressure at 1m from the each side of Cylinder Block					
(without Fan)	dB(A)	98.3	100.7	98.3	100.7

The all data and the specific fuel consumption are based on ISO 3046/1, Standard reference conditions are in accordance with 298 K(25° Celsius) air temperature, 100kPa(1000mbar) air pressure, 60% relative humidity, 110m(361ft) altitude.

Operation At Elevated Temperature And Altitude: The engine may be operated at :

1800 rpm & 1500rpm up to 750~ 1000m and 30°C without power deration

For sustained operation above these conditions, derate by 3% per 304m , and 2% per 11 °C

Engine Data with Dry Type Exhaust Manifold

○ Intake Air Flow	m3/min	13.49	20.19	14.33	21.28
○ Exhaust gas temp. after turbo.	°C	137	543	610	582
○ Exhaust Gas Flow	m3/min	-	40.9	33.9	44.6
○ Heat Rejection to Exhaust	kW	118.8	145.5	133.6	162.0
○ Heat Rejection to Coolant	kW	51.6	63.3	58.1	70.4
○ Heat Rejection to Intercooler	kW	-	-	-	-
○ Radiated Heat to Ambient	kW	12.0	14.8	13.5	16.4
○ Cooling water circulation	liters/min	130	150	130	150
○ Cooling fan air flow	m3/min	190	224	190	224



◆ ENGINE DIMENSION

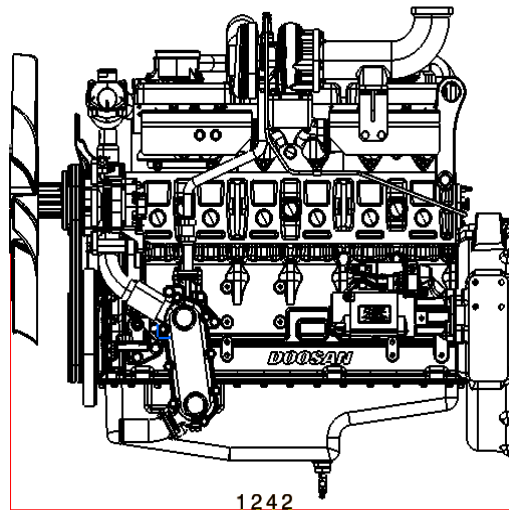
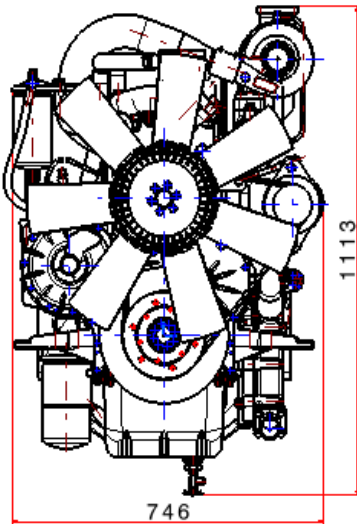

◆ CONVERSION TABLE

in. = mm x 0.0394

PS = kW x 1.3596

psi = kg/cm² x 14.2233

in³ = lit. x 61.02

hp = PS x 0.98635

lb = kg x 2.20462

kW = Kcal/sec x 0.239

lb/ft = N.m x 0.737

U.S. gal = lit. x 0.264

kW = 0.2388 kcal/s

lb/PS.h = g/kW.h x 0.00162

cfm = m³/min x 35.336

Mpa = Pa x 1000 = bar x 10

Doosan Infracore Co., Ltd.

21st Floor, Doosan Tower, 18-12, Euljiro 6-ga,
Jung-gu, Seoul, Korea.

TEL : +82-2-3398-8578 / FAX : +82-2-3398-8509

E-mail : enginesales@doosan.com

Web site : www.doosaninfracore.com

※ Specifications are subject to change without prior notice